

Part Number:
TW Locking Comb

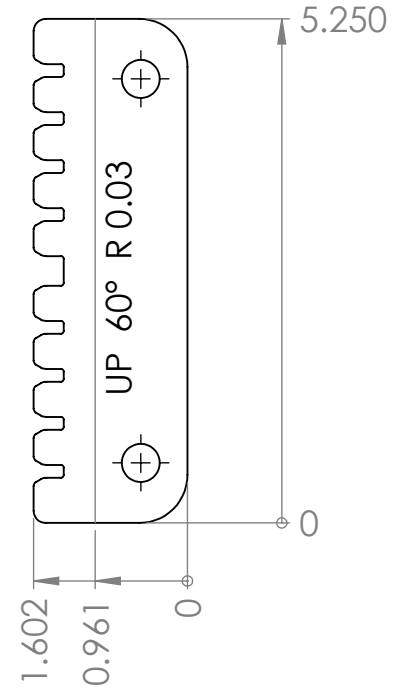
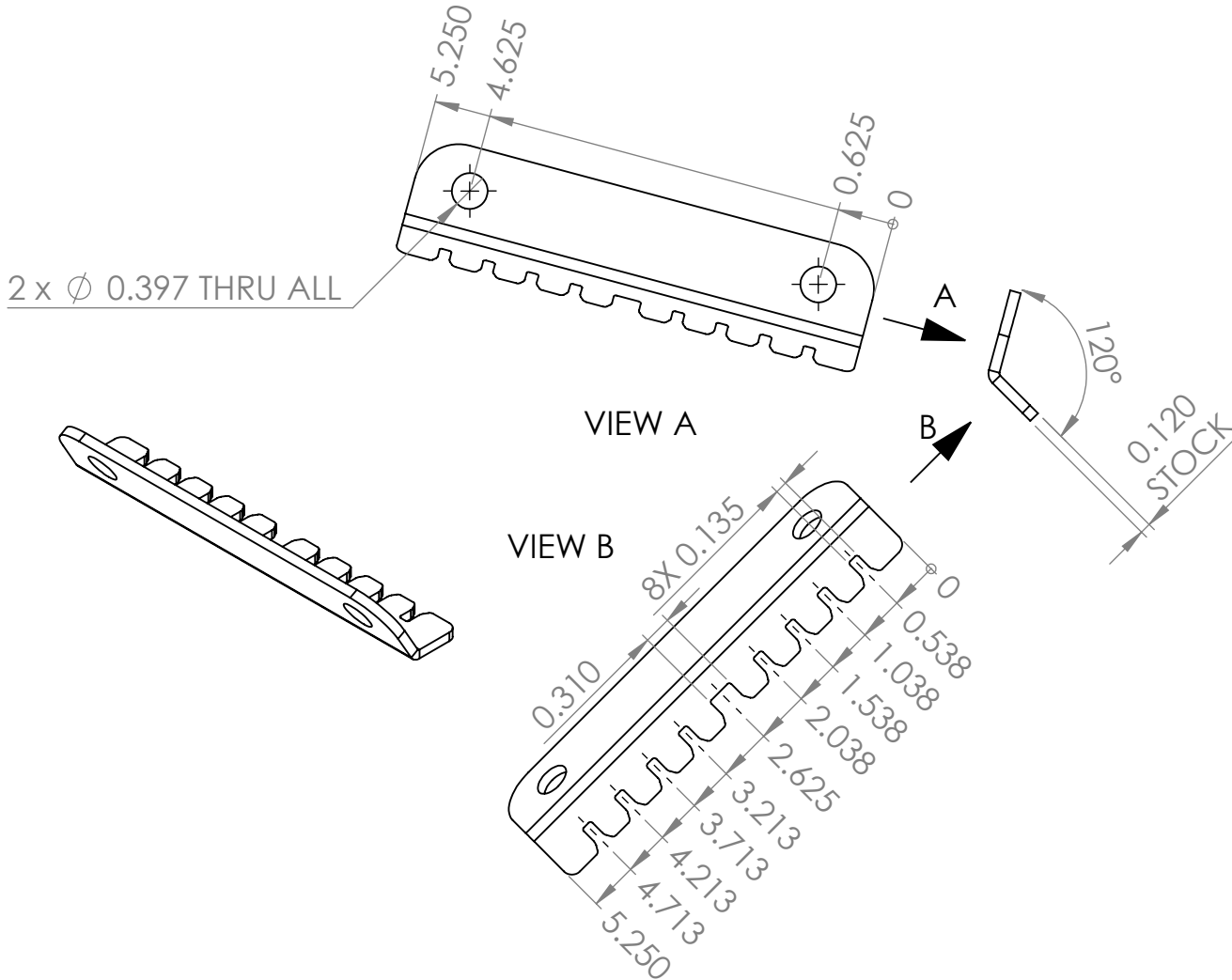

2 x ϕ 0.397 THRU ALL

VIEW A

VIEW B

120°
0.120 STOCK

1.602
0.961
0



PROPRIETARY AND CONFIDENTIAL
THE INFORMATION CONTAINED IN THIS DRAWING IS THE SOLE PROPERTY OF TH FABRICATION, LLC. ANY REPRODUCTION IN PART OR AS A WHOLE WITHOUT THE WRITTEN PERMISSION OF TH FABRICATION, LLC IS PROHIBITED.

REVISION NOTES

REV	REVISION DESCRIPTION	DATE	AUTHOR
1			
2			
3			
4			

CLIENT:	NAME	DATE
UNLESS OTHERWISE SPECIFIED:	DRAWN	
DIMENSIONS ARE IN INCHES	CHECKED	
TOLERANCES:	ENG APPR.	
FRACTIONAL \pm 1/16"	MATERIAL NOTES 11GA SHEET	
ANGULAR: MACH \pm .25 BEND \pm 1		
TWO PLACE DECIMAL \pm .062"		
THREE PLACE DECIMAL \pm .031"		
MATERIAL SPECS	Plain Carbon Steel	
FINISH	Powdercoat	
DO NOT SCALE DRAWING		

TH Fabrication, LLC
www.th-fabrication.com

Part Number:

TW Locking Comb

SIZE	Description:	REV
A		
SCALE: 1:2	WEIGHT:	SHEET 1 OF 1