

2

1

Part Number:
TW Locking Bracket

B

B

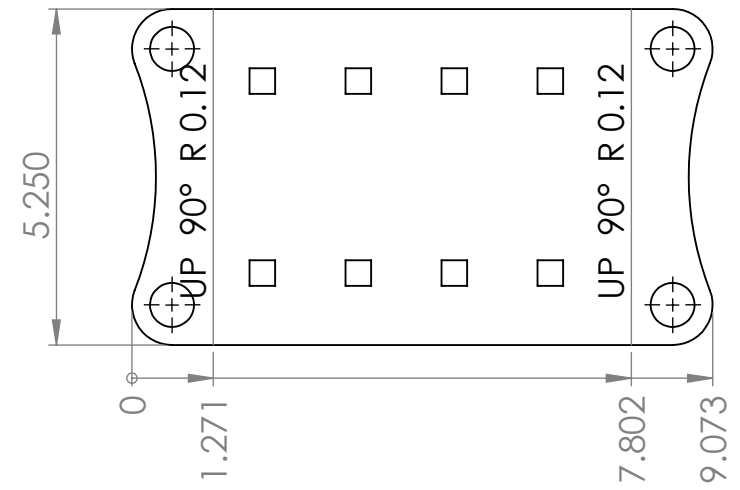
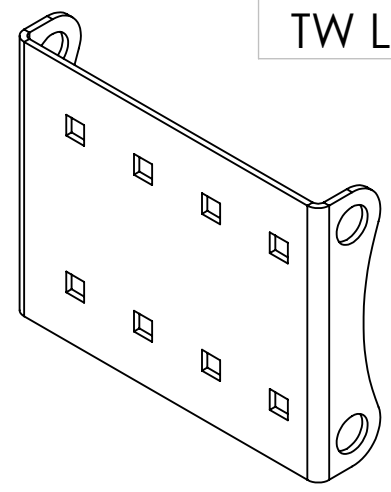
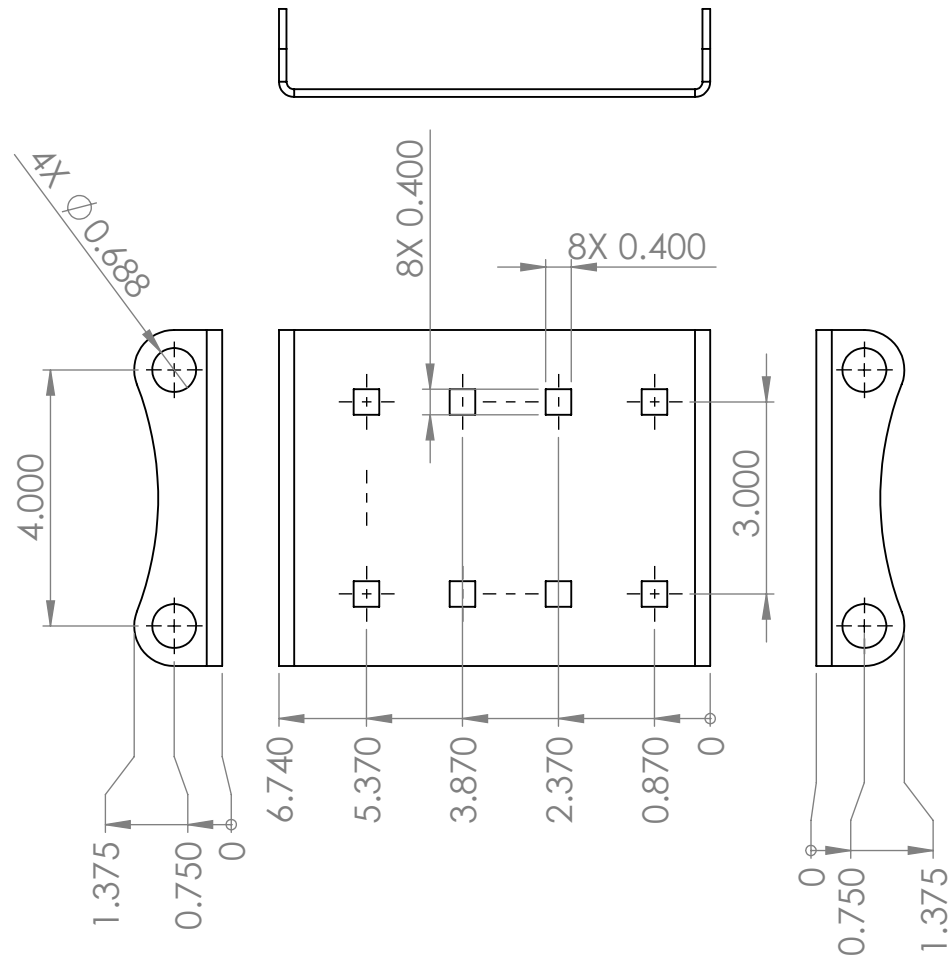

A

A



PROPRIETARY AND CONFIDENTIAL
 THE INFORMATION CONTAINED IN THIS DRAWING IS THE SOLE PROPERTY OF TH FABRICATION, LLC. ANY REPRODUCTION IN PART OR AS A WHOLE WITHOUT THE WRITTEN PERMISSION OF TH FABRICATION, LLC IS PROHIBITED.

CLIENT:

NAME DATE

UNLESS OTHERWISE SPECIFIED:
 DIMENSIONS ARE IN INCHES
 TOLERANCES:
 FRACTIONAL ± 1/16"
 ANGULAR: MACH ± .25 BEND ± 1
 TWO PLACE DECIMAL ± .062"
 THREE PLACE DECIMAL ± .031"

DRAWN
 CHECKED
 ENG APPR.

TH Fabrication, LLC
www.th-fabrication.com

REVISION NOTES

REV	REVISION DESCRIPTION	DATE	AUTHOR
1			
2			
3			
4			

MATERIAL NOTES

11GA SHEET

MATERIAL SPECS
 Plain Carbon Steel
 FINISH
 Powdercoat
 DO NOT SCALE DRAWING

Part Number:
TW Locking Bracket

SIZE Description: REV
A
 SCALE: 1:3 WEIGHT: SHEET 1 OF 1

2

1