

4

3

2

1

ITEM NO.	PART NUMBER	DESCRIPTION	QTY.
1	VIAIR 280C.STP		1
2	VIAIR_20005_TANK		1
3	7465K67_ARO NUMBER 1000 AIR FILTER FOR PARTICLES	ARO NUMBER 1000 AIR FILTER FOR PARTICLES	1
4	EGIS BREAKER SWITCH CASE.STEP	EGIS BREAKER SWITCH CASE	1
5	EGIS BREAKER SWITCH BUTTON.STEP	EGIS BREAKER SWITCH BUTTON	1
6	4000K816	DUAL SCALE PRESSURE GAUGE WITH STEEL CASE	1
7	AIRSYS_POWERUNIT_ENCLOSUREMAIN		1
8	AIRSYS_POWERUNIT_AIRBRACKET		1
9	92196A226	18-8 STAINLESS STEEL SOCKET HEAD SCREW	2
10	5779K635	PUSH-TO-CONNECT TUBE FITTING FOR AIR	1
11	5779K109	PUSH-TO-CONNECT TUBE FITTING FOR AIR	4
12	50785K222	HIGH-PRESSURE BRASS PIPE FITTING	1
13	50785K273	HIGH-PRESSURE BRASS PIPE FITTING	3
14	5779K119	PUSH-TO-CONNECT TUBE FITTING FOR AIR	1
15	5779K162	PUSH-TO-CONNECT TUBE FITTING FOR AIR	2
16	6534K16	INDUSTRIAL QUICK-DISCONNECT HOSE COUPLING FOR AIR	1
17	5779K152	PUSH-TO-CONNECT TUBE FITTING FOR AIR	2
18	6534K46	INDUSTRIAL QUICK-DISCONNECT HOSE COUPLING FOR AIR	2
19	9307K52	BUNA-N RUBBER GROMMETS	1
20	9307K13	BUNA-N RUBBER GROMMETS	3
21	92196A272	18-8 STAINLESS STEEL SOCKET HEAD SCREW	2
22	90101A225	18-8 STAINLESS STEEL THIN NYLON-INSERT LOCKNUT	4
23	AIRSYS_POWERUNIT_ENCLOSUREPANEL		1
24	AIRSYS_POWERUNIT_TOOLBARBRACKET		2
25	3060T68	SQUARE U-BOLT	2
26	6534K26	INDUSTRIAL QUICK-DISCONNECT HOSE COUPLING FOR AIR	2
27	3846K455	SINGLE SCALE PRESSURE GAUGE WITH STEEL CASE	2
28	7465K592	ARO COMPRESSED AIR FRL	2
29	5111K385	PUSH-TO-CONNECT TUBE FITTING FOR AIR AND WATER	2
30	5779K151	PUSH-TO-CONNECT TUBE FITTING FOR AIR	1
31	RAM-347U		1
32	AIRSYS_UI_HOUSING_OUTER		1
33	AIRSYS_UI_HOUSING_SPACER		4
34	AIRSYS_UI_PANEL_FRONT		1
35	AIRSYS_UI_PANEL_BACK		1
36	92196A285	18-8 STAINLESS STEEL SOCKET HEAD SCREW	4
37	4638K511	LOW-PRESSURE PIPE FITTING	1
38	5779K204	PUSH-TO-CONNECT TUBE FITTING FOR AIR	3
39	50785K25	HIGH-PRESSURE BRASS PIPE FITTING	3
40	50785K41	HIGH-PRESSURE BRASS PIPE FITTING	3
41	6534K56	INDUSTRIAL QUICK-DISCONNECT HOSE COUPLING FOR AIR	1

Part Number:

AirSys

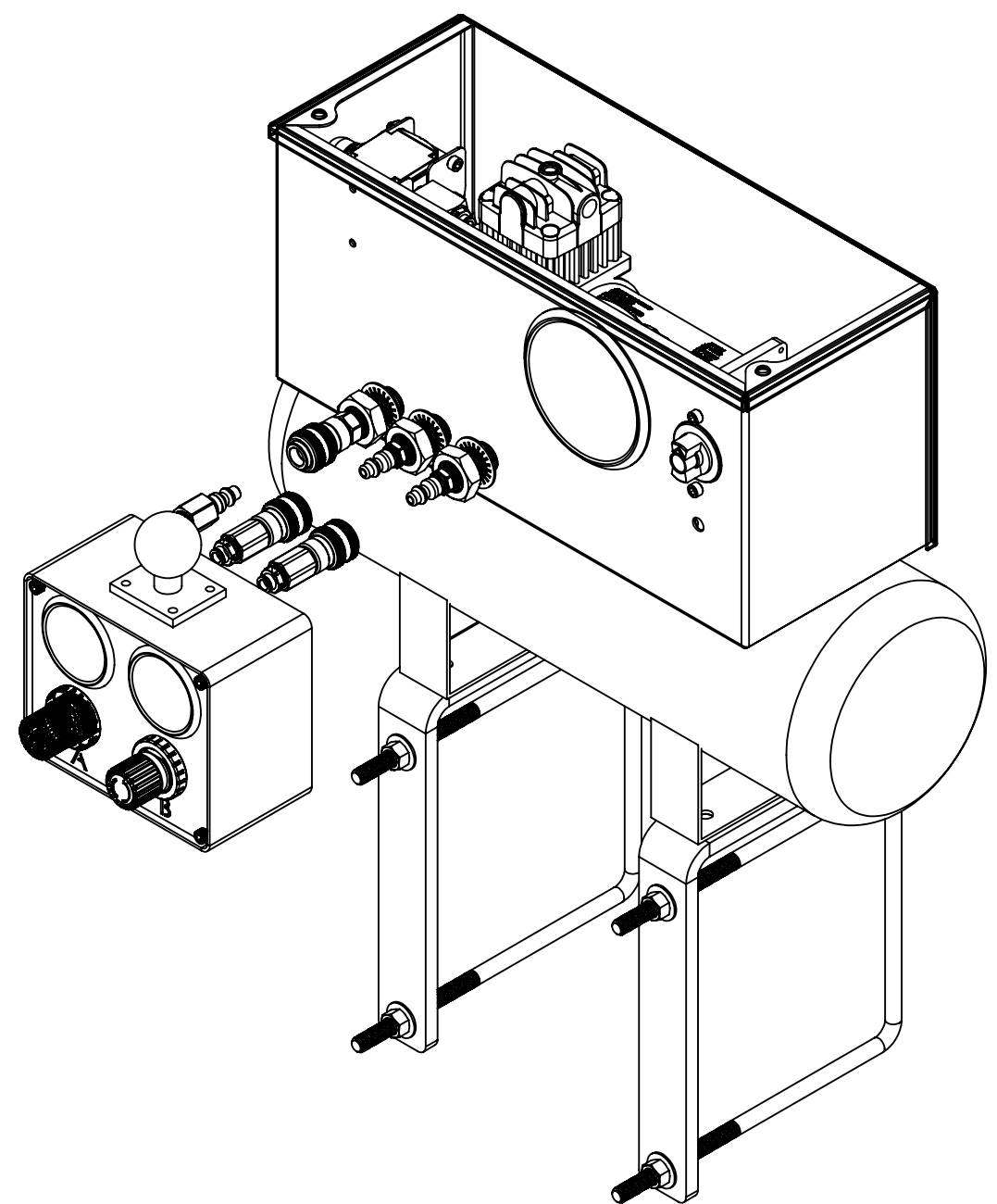

B

B

A

A



PROPRIETARY AND CONFIDENTIAL
 THE INFORMATION CONTAINED IN THIS DRAWING IS THE SOLE PROPERTY OF TH FABRICATION, LLC. ANY REPRODUCTION IN PART OR AS A WHOLE WITHOUT THE WRITTEN PERMISSION OF TH FABRICATION, LLC IS PROHIBITED.

REV	REVISION DESCRIPTION	DATE	AUTHOR
1			
2			
3			
4			

CLIENT:	NAME	DATE
UNLESS OTHERWISE SPECIFIED:	DRAWN	
DIMENSIONS ARE IN INCHES	CHECKED	
TOLERANCES:	ENG APPR.	
FRACTIONAL ± 1/16"	MATERIAL NOTES	
ANGULAR: MACH ± .25 BEND ± 1		
TWO PLACE DECIMAL ± .062"		
THREE PLACE DECIMAL ± .031"		
MATERIAL		
FINISH		
DO NOT SCALE DRAWING		

TH Fabrication, LLC

www.th-fabrication.com

DWG. NO.

AirSys

SIZE TITLE: REV

B

SCALE: 1:4 WEIGHT: SHEET 1 OF 1

4

3

2

1